

4M BIT (256K WORD × 16 BIT/512K WORD × 8BIT) CMOS MASK ROM

### DESCRIPTION

The TC534200P/F is a 4,194,304 bits read only memory organized as 262,144 words by 16 bits when BYTE is logical high, and is organized as 524,288 words by 8 bits when BYTE is logical low.

The TC534200P/F is most suitable for the program memory, data memory, and character generator.

The TC534200P/F is packaged in a standard 600mil 40pin DIP, or 525mil 40 pin SOP.

### FEATURES

- Single 5V Power Supply
- Access Time : 150ns (Max.)
- Power Dissipation
  - Operating Current : 50mA (Max.)
  - Standby Current : 20 $\mu$ A (Max.)
- Fully Static Operation
- All Inputs and Outputs : TTL Compatible
- Three State Outputs
- TC534200P : DIP40-P-600
- TC534200F : SOP40-P-525

### PIN CONNECTION (TOP VIEW)

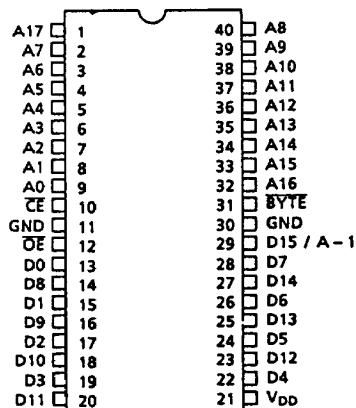

### PIN NAMES

A0~A17	Address inputs
D0~D14	Data Outputs
$\overline{CE}$	Chip Enable Input
$\overline{OE}$	Output Enable Input
D15 / A-1	Data Output / Address Input
<u>BYTE</u>	Word, Byte selection Input
V <sub>DD</sub>	Power Supply
GND	Ground

## BLOCK DIAGRAM

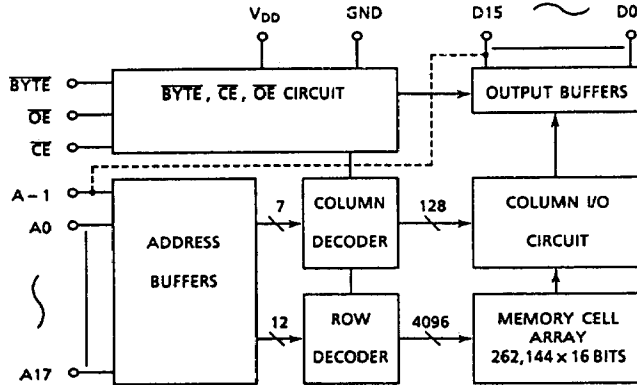

## MODE SELECTION

MODE	CE	OE	BYTE	D0 - D7	D8 - D14	D15 / A - 1	Power
Read (16 Bit)	L	L	H	Data Out			Active
Read (8 Bit)	L	L	L	Data Out (Lower 8bit)	High Impedance	L	Active
Read (8 Bit)	L	L	L	Data Out (Upper 8bit)	High Impedance	H	Active
Output Deselect	L	H	*	High Impedance			Active
Standby	H	*	*	High Impedance			Standby

H :  $V_{IH}$  L :  $V_{IL}$  \* :  $V_{IH}$  or  $V_{IL}$

## MAXIMUM RATINGS

SYMBOL	ITEM	RATING	UNIT
$V_{DD}$	Power Supply Voltage	-0.5~7.0	V
$V_{IN}$	Input Voltage	-0.5~ $V_{DD}$	V
$V_{OUT}$	Output Voltage	0~ $V_{DD}$	V
$P_D$	Power Dissipation	1.0/0.6*	W
$T_{STG}$	Storage Temperature	-55~150	°C
$T_{OPR}$	Operating Temperature	0~70	°C
$T_{SOLDER}$	Soldering Temperature · Time	260 · 10	°C · sec

\*.SOP

## D.C. OPERATING CONDITIONS (Ta = 0~70°C)

SYMBOL	PARAMETER	MIN.	TYP.	MAX.	UNIT
V <sub>DD</sub>	Power Supply Voltage	4.5	5.0	5.5	V
V <sub>IH</sub>	Input High Voltage	2.2	-	V <sub>DD</sub> + 0.3	V
V <sub>IL</sub>	Input Low Voltage	-0.3	-	0.8	V

## D.C. and OPERATING CHARACTERISTICS (Ta = 0~70°C)

SYMBOL	PARAMETER	CONDITIONS	MIN.	MAX.	UNIT
I <sub>IL</sub>	Input Leakage Current	V <sub>IN</sub> = 0~V <sub>DD</sub>	-	± 1.0	μA
I <sub>LO</sub>	Output Leakage Current	V <sub>OUT</sub> = 0~V <sub>DD</sub>	-	± 5.0	μA
I <sub>OH</sub>	Output High Current	V <sub>OH</sub> = 2.4V	- 1.0	-	mA
I <sub>OL</sub>	Output Low Current	V <sub>OL</sub> = 0.4V	2.0	-	mA
I <sub>DDs1</sub>	Standby Current	CE = V <sub>IH</sub>	-	2	mA
I <sub>DDs2</sub>		CE = V <sub>DD</sub> - 0.2V	-	20	μA
I <sub>DDO1</sub>	Operating Current	V <sub>IN</sub> = V <sub>IH</sub> / V <sub>IL</sub> , t <sub>cycle</sub> = 150ns	-	60	mA
I <sub>DDO2</sub>		V <sub>IN</sub> = V <sub>DD</sub> - 0.2V / 0.2V, t <sub>cycle</sub> = 150ns	-	50	mA

## CAPACITANCE f = 1MHz, Ta = 25°C

SYMBOL	PARAMETER	CONDITIONS	MIN.	MAX.	UNIT
C <sub>IN</sub>	Input Capacitance	V <sub>IN</sub> = 0V	-	10	pF
C <sub>OUT</sub>	Output Capacitance	V <sub>OUT</sub> = 0V	-	12	pF

Note : This Parameter is periodically sampled and is not 100% tested.

## A.C. CHARACTERISTICS (Ta = 0~70°C, VDD = 5V ± 10%)

SYMBOL	PARAMETER	MIN.	MAX.	UNIT
t <sub>CYC</sub>	Cycle Time	150	-	ns
t <sub>ACC</sub>	Address Access Time	-	150	ns
t <sub>CE</sub>	Chip Enable Access Time	-	150	ns
t <sub>BT</sub>	BYTE Access Time	-	150	ns
t <sub>OE</sub>	Output Enable Access Time	-	70	ns
t <sub>CE0</sub>	Output Disable Time from CE	-	60	ns
t <sub>OE0</sub>	Output Disable Time from OE	-	60	ns
t <sub>BT0</sub>	Output Disable Time from BYTE	-	60	ns
t <sub>OH</sub>	Output Hold Time	5	-	ns

### A.C. TEST CONDITIONS

Output Load : 100pF + 1TTL  
 Input Levels : 0.6V, 2.4V  
 Timing Measurement Reference Levels Input : 0.8V, 2.2V  
 Output : 0.8V, 2.0V  
 Input Rise and Fall Time : 5ns

### TIMING WAVEFORMS

#### WORD-WIDE READ MODE

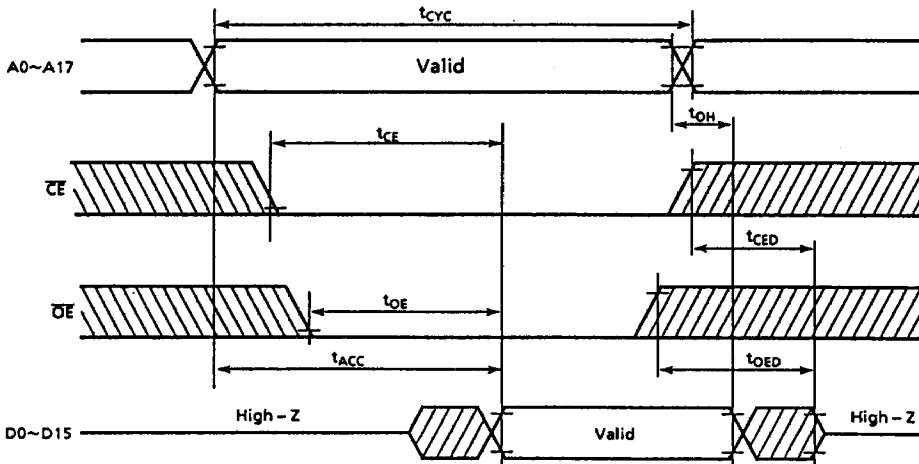

Note: BYTE = V<sub>IH</sub>

BYTE - WIDE READ MODE

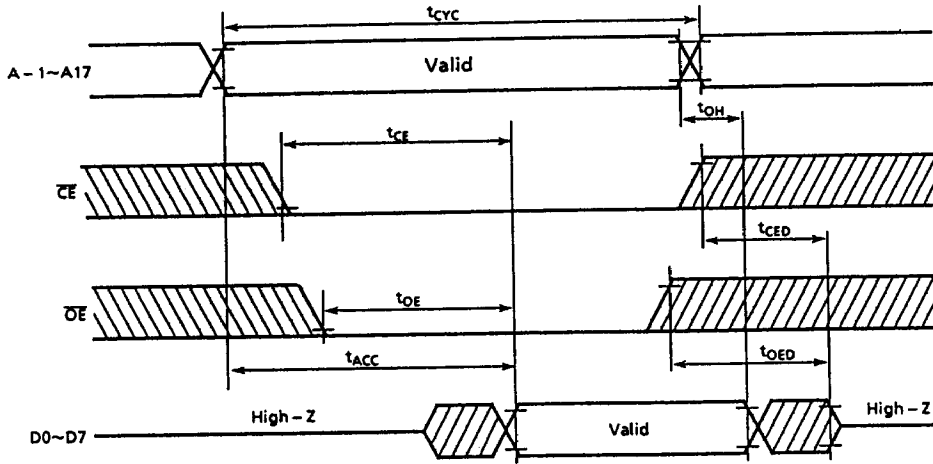

Note:  $\overline{BYTE} = V_{IL}$

BYTE TRANSITION

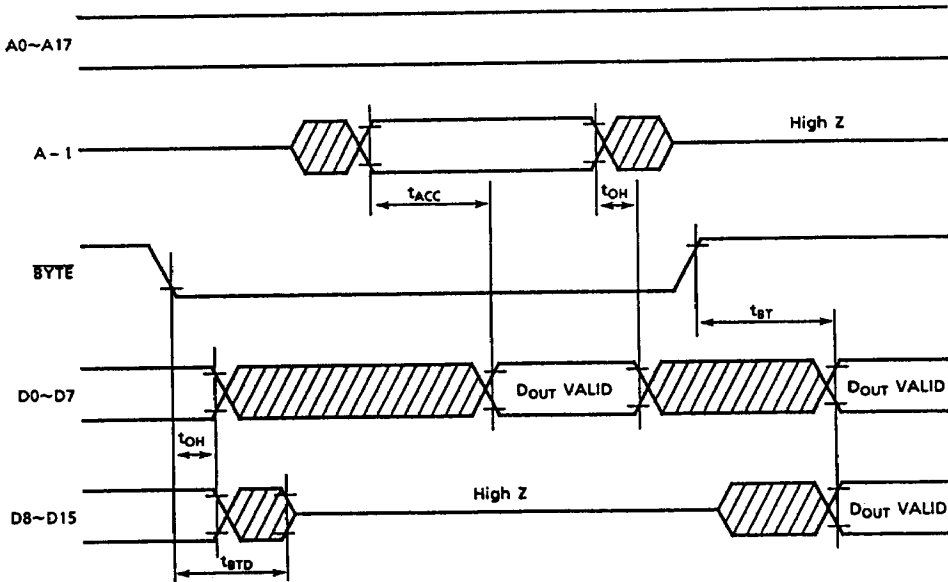

Note:  $\overline{CE} = V_{IL}$ ,  $\overline{OE} = V_{IL}$

# TC534200P/F-15

## OUTLINE DRAWINGS

- Plastic DIP

DIP40-P-600

Unit : mm

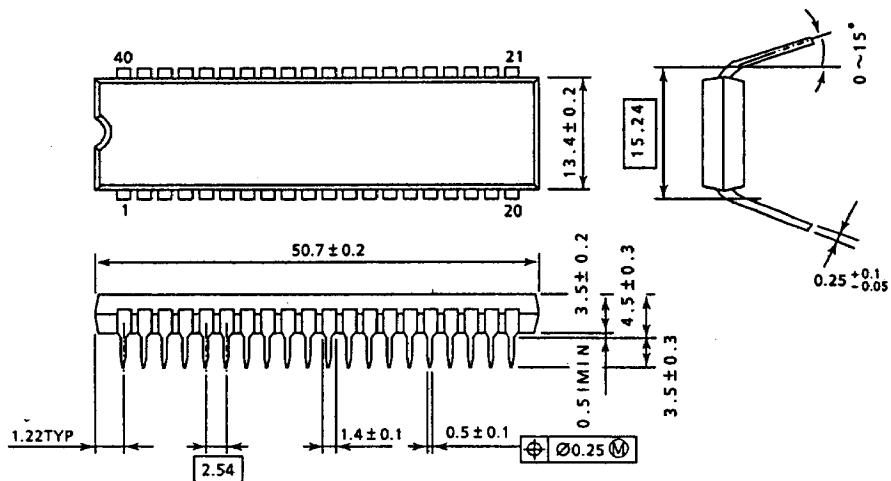

Note : Package width and length do not include mold protrusion, allowable mold protrusion is 0.15mm.

OUTLINE DRAWINGS

- Plastic SOP
- SOP40-P-525

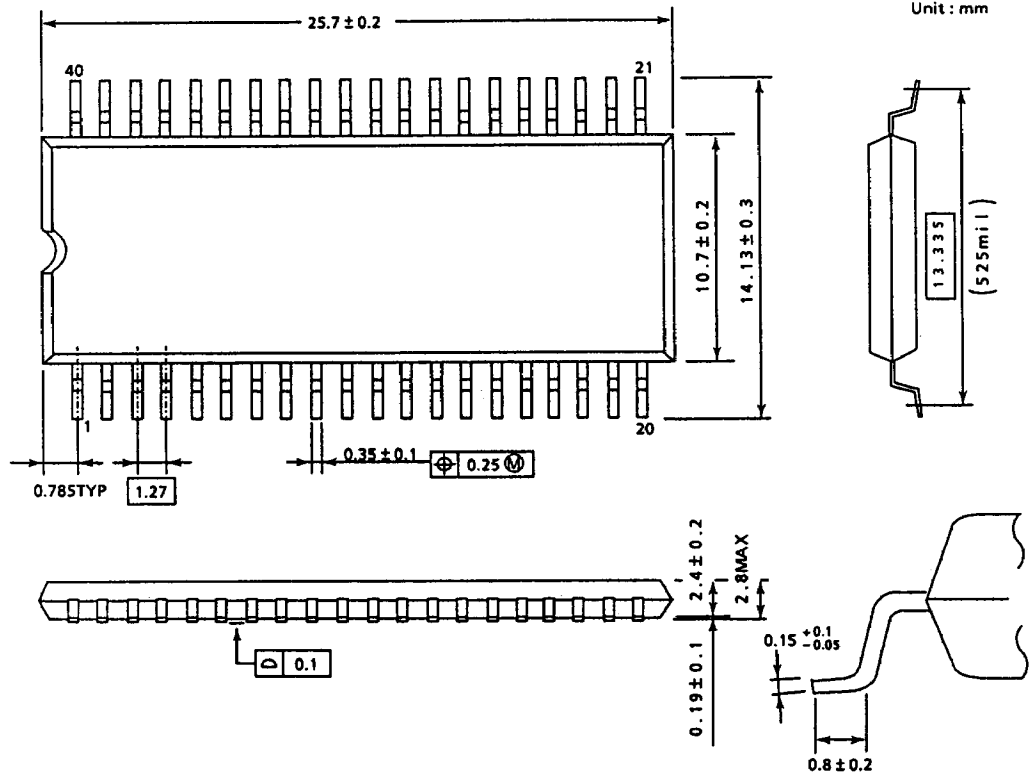

Note : Package width and length do not include mold protrusion, allowable mold protrusion is 0.15mm.