

✓ 54S/74S189 011745
 ✓ 54LS/74LS189 011750

64-BIT RANDOM ACCESS MEMORY
 (With 3-State Outputs)

DESCRIPTION — The '189 is a high speed 64-bit RAM organized as a 16-word by 4-bit array. Address inputs are buffered to minimize loading and are fully decoded on-chip. The outputs are 3-state and are in the high impedance state whenever the Chip Select (\overline{CS}) input is HIGH. The outputs are active only in the Read mode and the output data is the complement of the stored data.

- 3-STATE OUTPUTS FOR DATA BUS APPLICATIONS
- BUFFERED INPUTS MINIMIZE LOADING
- ADDRESS DECODING ON-CHIP
- DIODE CLAMPED INPUTS MINIMIZE RINGING

ORDERING CODE: See Section 9

PKGS	PIN OUT	COMMERCIAL GRADE	MILITARY GRADE	PKG TYPE
		$V_{CC} = +5.0\text{ V} \pm 5\%$, $T_A = 0^\circ\text{C to } +70^\circ\text{C}$	$V_{CC} = +5.0\text{ V} \pm 10\%$, $T_A = -55^\circ\text{C to } +125^\circ\text{C}$	
Plastic DIP (P)	A	74S189PC, 74LS189PC		9B
Ceramic DIP (D)	A	74S189DC, 74LS189DC	54S189DM, 54LS189DM	6B
Flatpak (F)	A	74S189FC, 74LS189FC	54S189FM, 54LS189FM	4L

CONNECTION DIAGRAM
 PINOUT A

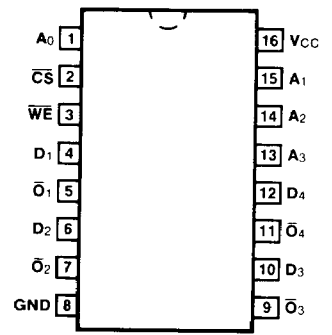

LOGIC SYMBOL

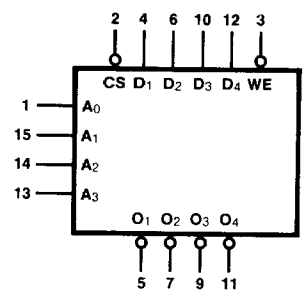

$V_{CC} = \text{Pin } 16$
 $GND = \text{Pin } 8$

INPUT LOADING/FAN-OUT: See Section 3 for U.L. definitions

PIN NAMES	DESCRIPTION	54/74S (U.L.) HIGH/LOW	54/74LS (U.L.) HIGH/LOW
$A_0 - A_3$	Address Inputs	0.63/0.16	0.5/0.013
\overline{CS}	Chip Select Input (Active LOW)	0.63/0.16	0.5/0.013
\overline{WE}	Write Enable Input (Active LOW)	0.63/0.16	0.5/0.013
$D_1 - D_4$	Data Inputs	0.63/0.16	0.5/0.013
$\overline{O}_1 - \overline{O}_4$	Inverted Data Outputs	162/10 (50)	10/10 (5.0)

FUNCTION TABLE

INPUTS		OPERATION	CONDITION OF OUTPUTS
\overline{CS}	\overline{WE}		
L	L	Write	High Impedance
L	H	Read	Complement of Stored Data
H	X	Inhibit	High Impedance

H = HIGH Voltage Level
 L = LOW Voltage Level
 X = Immaterial

LOGIC DIAGRAM

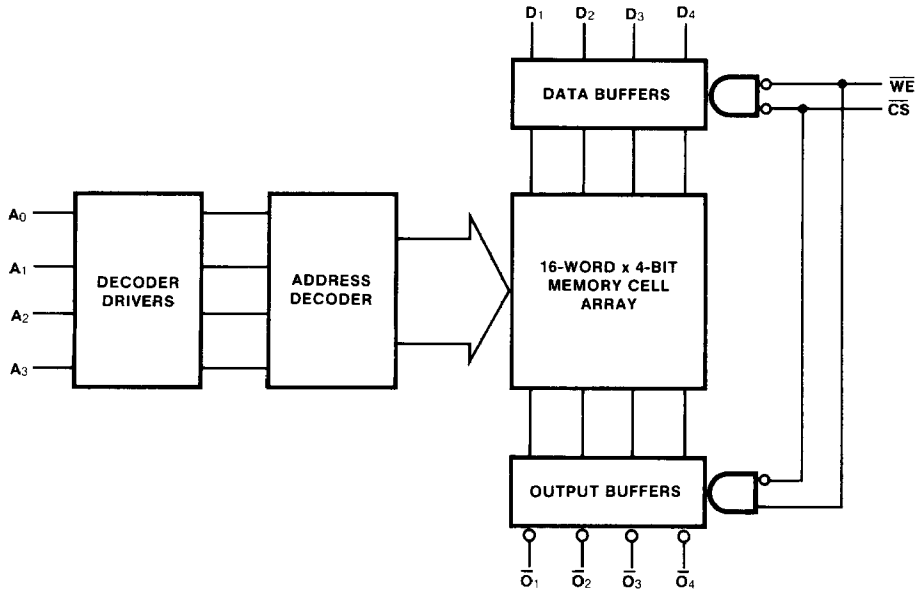

DC CHARACTERISTICS OVER OPERATING TEMPERATURE RANGE (unless otherwise specified)

SYMBOL	PARAMETER	54/74S		54/74LS		UNITS	CONDITIONS
		Min	Max	Min	Max		
VOL	Output LOW Voltage	XM	0.5	0.4	V	V _{CC} = Min I _{OL} = 16 mA ('S189) I _{OL} = 8.0 mA (54LS189) I _{OL} = 16 mA (74LS189)	
		XC	0.45	0.5			
VOH	Output HIGH Voltage	XM	2.4	2.8	V	V _{CC} = Min I _{OH} = 2.0 mA (54S189) I _{OH} = 6.5 mA (74S189) I _{OH} = 0.4 mA ('LS189)	
		XC	2.4	2.8			
I _{OS}	Output Short Circuit Current	-30	-100	-80*	mA	V _{CC} = Max	
I _{CC}	Power Supply Current	110		40	mA	V _{CC} = Max; \overline{WE} , \overline{CS} , Gnd	

*Typical Value

AC CHARACTERISTICS OVER RECOMMENDED V_{CC} AND T_A RANGE (unless otherwise specified)

SYMBOL	PARAMETER	54/74S		54/74LS		UNITS	CONDITIONS
		C _L = 30 pF R _L = 300 Ω		C _L = 15 pF			
		Min	Max	Min	Max		
t _{PLH} t _{PHL}	Access Time, HIGH or LOW, A _n to \overline{O}_n	XM XC	50 35	37* 37*	ns	Figs. 3-1, 3-20	
t _{PZH} t _{PZL}	Access Time, HIGH or LOW, \overline{CS} to \overline{O}_n	XM XC	32 22	10* 10*	ns	Figs. 3-3, 3-11, 3-12 R _L = 2 kΩ ('LS189)	
t _{PHZ}	Disable Time \overline{CS} to \overline{O}_n	XM XC	25 25		ns	Figs. 3-3, 3-11, 3-12 R _L = 2 kΩ ('LS189) C _L = 5 pF	
t _{PLZ}	Disable Time CS to \overline{O}_n	XM XC	25 17				
t _{PZH} t _{PZL}	Access Time, HIGH or LOW, \overline{WE} to \overline{O}_n	XM XC	40 30		ns	Figs. 3-3, 3-11, 3-12 R _L = 2 kΩ ('LS189)	
t _{PHZ}	Disable Time \overline{WE} to \overline{O}_n	XM XC	30 20		ns	Figs. 3-3, 3-11, 3-12 R _L = 2 kΩ ('LS189) C _L = 5 pF	
t _{PLZ}	Disable Time \overline{WE} to \overline{O}_n	XM XC	32 20				

AC OPERATING REQUIREMENTS OVER RECOMMENDED V_{CC} AND T_A RANGE (unless otherwise specified)

SYMBOL	PARAMETER	54/74S		54/74LS		UNITS	CONDITIONS
		Min	Max	Min	Max		
t _s (H) t _s (L)	Setup Time HIGH or LOW A _n to \overline{WE}	0		10*		ns	Fig. 3-21
t _h (H) t _h (L)	Hold Time HIGH or LOW A _n to \overline{WE}	0		0*		ns	
t _s (H) t _s (L)	Setup Time HIGH or LOW D _n to \overline{WE}	20		25*		ns	Fig. 3-13
t _h (H) t _h (L)	Hold Time HIGH or LOW D _n to \overline{WE}	0		0*		ns	
t _s (L)	Setup Time LOW \overline{CS} to \overline{WE}	0				ns	Fig. 3-14
t _h (L)	Hold Time LOW \overline{CS} to \overline{WE}	0				ns	Fig. 3-13
t _w (L)	\overline{WE} Pulse Width LOW	20		25*		ns	Fig. 3-14

*Typical Value