HM628128B Series

1 M SRAM (128-kword × 8-bit)

HITACHI

ADE-203-243E (Z)

Rev. 5.0

Nov. 1997

Description

The Hitachi HM628128B is a CMOS static RAM organized 131,072-word × 8-bit. It realizes higher density, higher performance and low power consumption by employing 0.8 μm Hi-CMOS shrink process technology. It offers low power standby power dissipation, therefore, it is suitable for battery backup systems. The device, packaged in a 525 mil SOP or a 8 mm × 20 mm TSOP or a 600 mil plastic DIP is available.

Features

- Single 5 V supply: 5.0 V ± 10%
- Access time: 70/75/85 ns (max)
- Power dissipation
 - Active: 50 mW/MHz (typ)
 - Standby: 10 μW (typ) (L/L-SL version)
- Completely static memory
 - No clock or timing strobe required
- Equal access and cycle times
- Common data input and output
 - Three state output
- Directly TTL compatible all inputs and outputs
- Capability of battery backup operation (L/L-SL version)
 - 2 chip selection for battery backup

HM628128B Series

Ordering Information

Type No.	Access time	Data retention current	Package
HM628128BLP-7	70 ns	50 μ A	600-mil 32-pin plastic DIP (DP-32)
HM628128BLP-8	85 ns	50 μ A	
HM628128BLP-7SL	70 ns	15 μ A	
HM628128BLP-8SL	85 ns	15 μ A	
HM628128BLFP-7	70 ns	50 μ A	525-mil 32-pin plastic SOP (FP-32D)
HM628128BLFP-75	75 ns	50 μ A	
HM628128BLFP-8	85 ns	50 μ A	
HM628128BLFP-7SL	70 ns	15 μ A	
HM628128BLFP-75SL	75 ns	15 μ A	
HM628128BLFP-8SL	85 ns	15 μ A	
HM628128BLT-7	70 ns	50 μ A	Normal-bend type 32-pin plastic 8 mm \times 20 mm TSOP (TFP-32D)
HM628128BLT-75	75 ns	50 μ A	
HM628128BLT-8	85 ns	50 μ A	
HM628128BLT-7SL	70 ns	15 μ A	
HM628128BLT-75SL	75 ns	15 μ A	
HM628128BLT-8SL	85 ns	15 μ A	
HM628128BLR-7	70 ns	50 μ A	Reverse-bend type 32-pin plastic 8 mm \times 20 mm TSOP (TFP-32DR)
HM628128BLR-8	85 ns	50 μ A	
HM628128BLR-7SL	70 ns	15 μ A	
HM628128BLR-8SL	85 ns	15 μ A	

Pin Arrangement

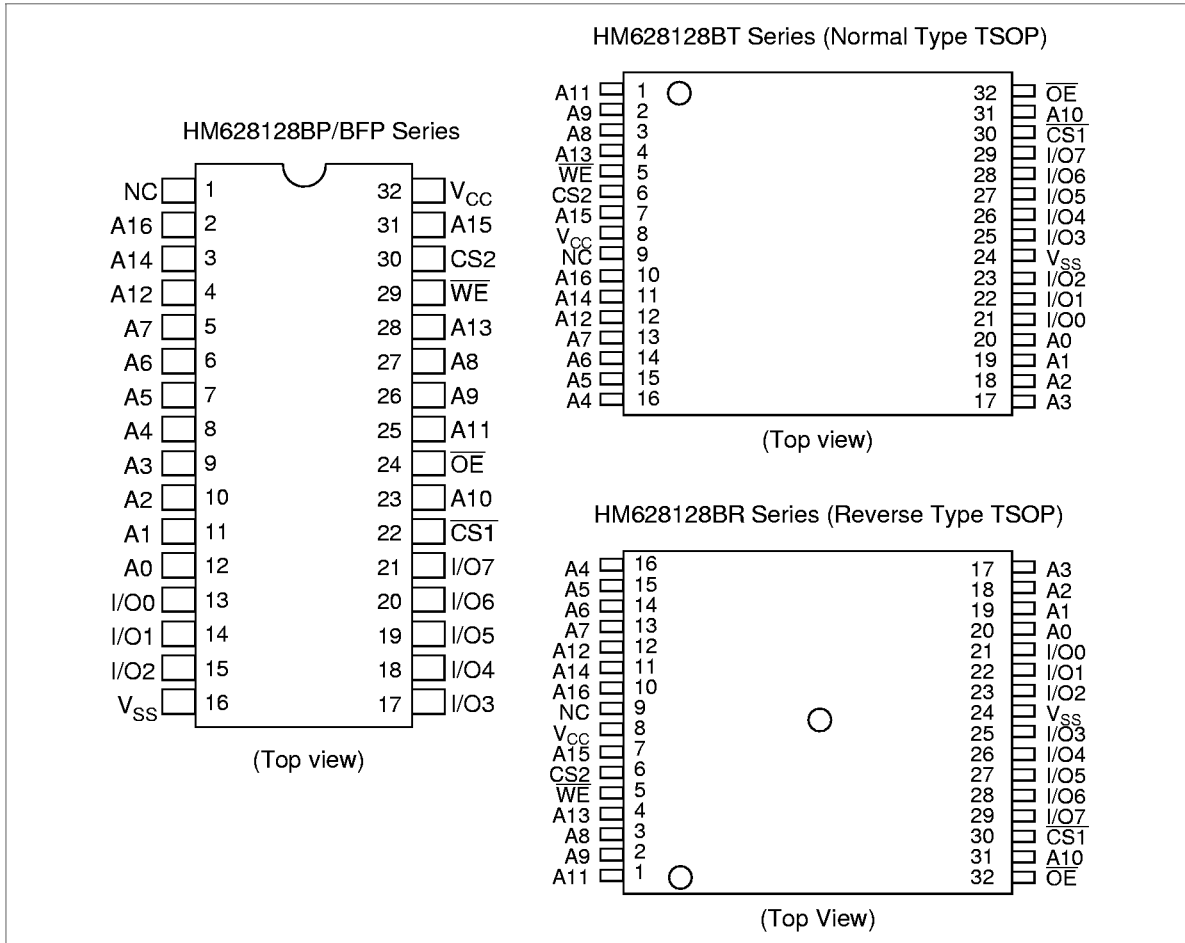

Pin Description

Pin name	Function
A0 to A16	Address input
I/O0 to I/O7	Data input/output
$\overline{CS1}$	Chip select 1
CS2	Chip select 2
\overline{WE}	Write enable
\overline{OE}	Output enable
NC	No connection
V _{CC}	Power supply
V _{SS}	Ground

HM628128B Series

Block Diagram

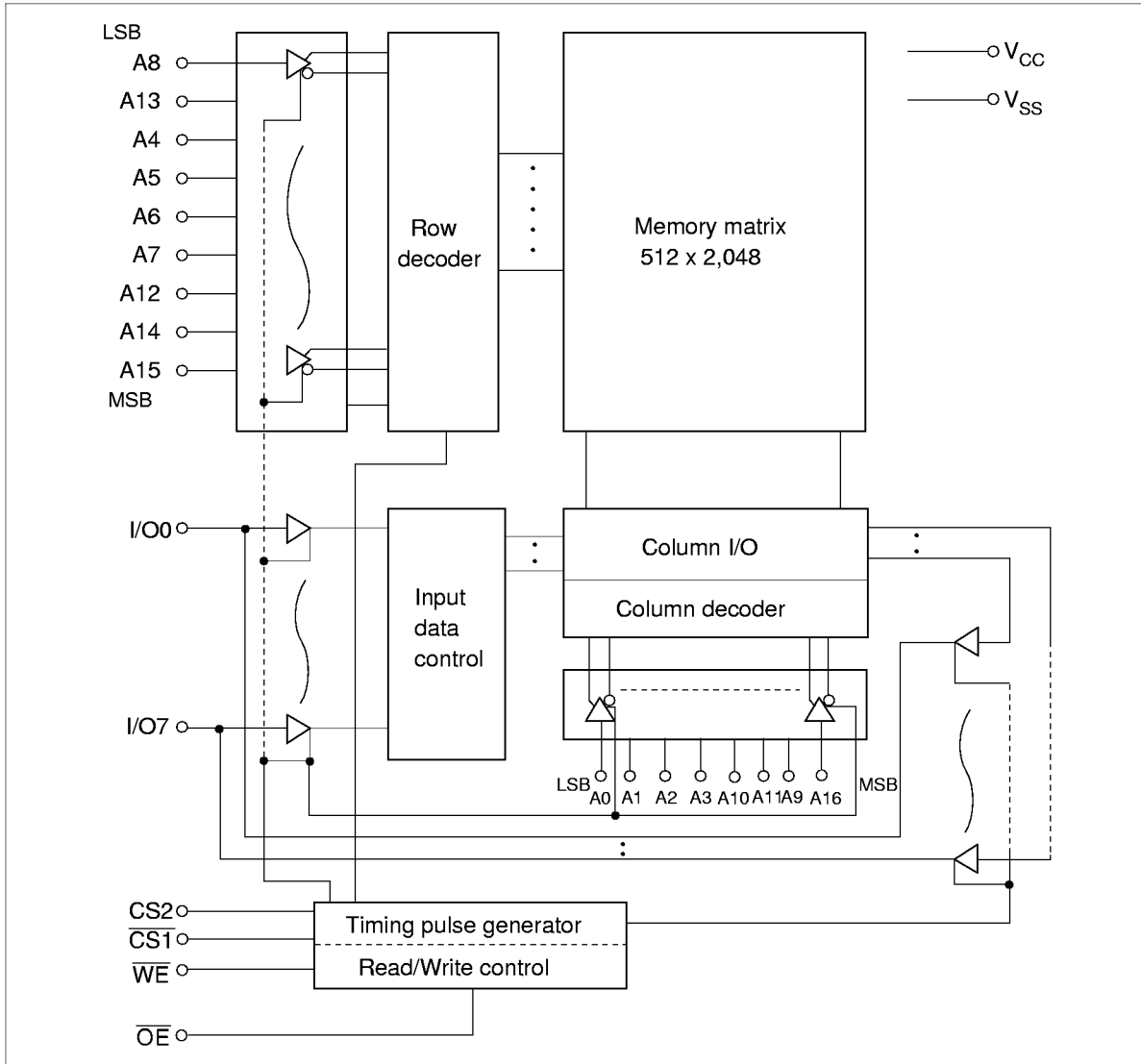

Function Table

\overline{WE}	$\overline{CS1}$	CS2	\overline{OE}	Mode	V_{CC} current	I/O pin	Ref. cycle
×	H	×	×	Standby	I_{SB}, I_{SB1}	High-Z	—
×	×	L	×	Standby	I_{SB}, I_{SB1}	High-Z	—
H	L	H	H	Output disable	I_{CC}	High-Z	—
H	L	H	L	Read	I_{CC}	Dout	Read cycle
L	L	H	H	Write	I_{CC}	Din	Write cycle (1)
L	L	H	L	Write	I_{CC}	Din	Write cycle (2)

Note: ×: H or L

Absolute Maximum Ratings

Parameter	Symbol	Value	Unit
Supply voltage relative to V_{SS}	V_{CC}	-0.5 to +7.0	V
Voltage on any pin relative to V_{SS}	V_T	-0.5* ¹ to $V_{CC} + 0.3$ * ²	V
Power dissipation	P_T	1.0	W
Operating temperature range	T_{opr}	0 to +70	°C
Storage temperature range	T_{stg}	-55 to +125	°C
Storage temperature under bias	T_{bias}	-10 to 85	°C

Notes: 1. V_T min: -3.0 V for pulse half-width ≤ 30 ns
 2. Maximum voltage is 7.0 V

Recommended DC Operating Conditions ($T_a = 0$ to +70°C)

Parameter	Symbol	Min	Typ	Max	Unit
Supply voltage	V_{CC}	4.5	5.0	5.5	V
	V_{SS}	0	0	0	V
Input high voltage	V_{IH}	2.2	—	$V_{CC} + 0.3$	V
Input low voltage	V_{IL}	-0.3* ¹	—	0.8	V

Note: 1. V_{IL} min: -3.0 V for pulse half-width ≤ 30 ns

HM628128B Series

DC Characteristics ($T_a = 0$ to $+70^\circ\text{C}$, $V_{CC} = 5\text{ V} \pm 10\%$, $V_{SS} = 0\text{ V}$)

Parameter	Symbol	Min	Typ* ¹	Max	Unit	Test conditions
Input leakage current	$ I_{LI} $	—	—	1	μA	$V_{in} = V_{SS}$ to V_{CC}
Output leakage current	$ I_{LO} $	—	—	1	μA	$\overline{CS1} = V_{IH}$ or $CS2 = V_{IL}$ or $OE = V_{IH}$ or $WE = V_{IL}$, $V_{I/O} = V_{SS}$ to V_{CC}
Operating current	I_{CC}	—	15	25	mA	$\overline{CS1} = V_{IL}$, $CS2 = V_{IH}$, Others = V_{IH}/V_{IL} , $I_{I/O} = 0\text{ mA}$
Average operating current	I_{CC1}	—	35	70	mA	Min cycle, duty = 100%, $\overline{CS1} = V_{IL}$, $CS2 = V_{IH}$, Others = V_{IH}/V_{IL} , $I_{I/O} = 0\text{ mA}$
	I_{CC2}	—	10	20	mA	Cycle time = $1\ \mu\text{s}$, duty = 100%, $I_{I/O} = 0\text{ mA}$, $\overline{CS1} \leq 0.2\text{ V}$, $CS2 \geq V_{CC} - 0.2\text{ V}$, Others = V_{IH}/V_{IL} $V_{IH} \geq V_{CC} - 0.2\text{ V}$, $V_{IL} \leq 0.2\text{ V}$
Standby current	I_{SB}	—	1	2	mA	$CS2 = V_{IL}$ or $\overline{CS1} = V_{IH}$, $CS2 = V_{IH}$
	I_{SB1}	—	2* ²	100* ²	μA	$0\text{ V} \leq V_{in} \leq V_{CC}$ (1) $0\text{ V} \leq CS2 \leq 0.2\text{ V}$ or (2) $\overline{CS1} \geq V_{CC} - 0.2\text{ V}$, $CS2 \geq V_{CC} - 0.2\text{ V}$
	I_{SB1}	—	2* ³	50* ³	μA	
Output high voltage	V_{OL}	—	—	0.4	V	$I_{OL} = 2.1\text{ mA}$
Output low voltage	V_{OH}	2.4	—	—	V	$I_{OH} = -1.0\text{ mA}$

Notes: 1. Typical values are at $V_{CC} = 5.0\text{ V}$, $T_a = +25^\circ\text{C}$ and not guaranteed.

2. This characteristic is guaranteed only for L version.

3. This characteristic is guaranteed only for L-SL version.

Capacitance ($T_a = 25^\circ\text{C}$, $f = 1.0\text{ MHz}$)

Parameter	Symbol	Min	Typ	Max	Unit	Test conditions
Input capacitance* ¹	C_{in}	—	—	8	pF	$V_{in} = 0\text{ V}$
Input/output capacitance* ¹	$C_{I/O}$	—	—	10	pF	$V_{I/O} = 0\text{ V}$

Note: 1. This parameter is sampled and not 100% tested.

AC Characteristics ($T_a = 0$ to $+70^\circ\text{C}$, $V_{CC} = 5.0\text{ V} \pm 10\%$)

Test Conditions

- Input pulse levels: 0.8 V to 2.4 V
- Input rise and fall time: 5 ns
- Input and output timing reference levels: 1.5 V
- Output load: 1 TTL Gate and C_L (100 pF) (Including scope and jig)

Read Cycle

Parameter	Symbol	HM628128B						Unit	Notes
		-7		-75		-8			
		Min	Max	Min	Max	Min	Max		
Read cycle time	t_{RC}	70	—	75	—	85	—	ns	
Address access time	t_{AA}	—	70	—	75	—	85	ns	
Chip selection to output valid	t_{CO1}	—	70	—	75	—	85	ns	
	t_{CO2}	—	70	—	75	—	85	ns	
Output enable to output valid	t_{OE}	—	35	—	35	—	45	ns	
Chip selection to output in low-Z	t_{LZ1}	10	—	10	—	10	—	ns	2, 3
	t_{LZ2}	10	—	10	—	10	—	ns	
Output enable to output in low-Z	t_{OLZ}	5	—	5	—	5	—	ns	2, 3
Chip deselection to output in high-Z	t_{HZ1}	0	25	0	25	0	30	ns	1, 2, 3
	t_{HZ2}	0	25	0	25	0	30	ns	
Output disable to output in high-Z	t_{OHZ}	0	25	0	25	0	30	ns	1, 2, 3
Output hold from address change	t_{OH}	10	—	10	—	10	—	ns	

HM628128B Series

Write Cycle

Parameter	Symbol	HM628128B						Unit	Notes
		-7		-75		-8			
		Min	Max	Min	Max	Min	Max		
Write cycle time	t_{WC}	70	—	75	—	85	—	ns	
Chip selection to end of write	t_{CW}	60	—	60	—	75	—	ns	5
Address setup time	t_{AS}	0	—	0	—	0	—	ns	6
Address valid to end of write	t_{AW}	60	—	60	—	75	—	ns	
Write pulse width	t_{WP}	50	—	50	—	55	—	ns	4, 13
Write recovery time	t_{WR}	0	—	0	—	0	—	ns	7
Write to output in high-Z	t_{WHZ}	0	25	0	25	0	30	ns	1, 2, 8
Data to write time overlap	t_{DW}	30	—	30	—	35	—	ns	
Data hold from write time	t_{DH}	0	—	0	—	0	—	ns	
Output active from end of write	t_{OW}	5	—	5	—	5	—	ns	2
Output disable to output in High-Z	t_{OHZ}	0	25	0	25	0	30	ns	1, 2, 8

- Notes:
- t_{HZ} , t_{OHZ} and t_{WHZ} are defined as the time at which the outputs achieve the open circuit conditions and are not referred to output voltage levels.
 - This parameter is sampled and not 100% tested.
 - At any given temperature and voltage condition, t_{HZ} max is less than t_{LZ} min both for a given device and from device to device.
 - A write occurs during the overlap of a low $\overline{CS1}$, a high CS2, and a low \overline{WE} . A write begins at the latest transition among $\overline{CS1}$ going low, CS2 going high, and \overline{WE} going low. A write ends at the earliest transition among $\overline{CS1}$ going high, CS2 going low, and \overline{WE} going high. t_{WP} is measured from the beginning of write to the end of write.
 - t_{CW} is measured from the later of $\overline{CS1}$ going low or CS2 going high to the end of write.
 - t_{AS} is measured from the address valid to the beginning of write.
 - t_{WR} is measured from the earliest of $\overline{CS1}$ or \overline{WE} going high or CS2 going low to the end of write cycle.
 - During this period, I/O pins are in the output state; therefore, the input signals of the opposite phase to the outputs must not be applied.
 - If $\overline{CS1}$ goes low simultaneously with \overline{WE} going low or after \overline{WE} going low, the outputs remain in a high impedance state.
 - Dout is the same phase of the latest written data in this write cycle.
 - Dout is the read data of next address.
 - If $\overline{CS1}$ is low and CS2 high during this period, I/O pins are in the output state. Therefore, the input signals of the opposite phase to the outputs must not be applied to them.
 - In the write cycle with \overline{OE} low fixed, t_{WP} must satisfy the following equation to avoid a problem of data bus contention.

$$t_{WP} \geq t_{DW} \text{ min} + t_{WHZ} \text{ max}$$

Timing Waveform

Read Timing Waveform ($\overline{WE} = V_{IH}$)

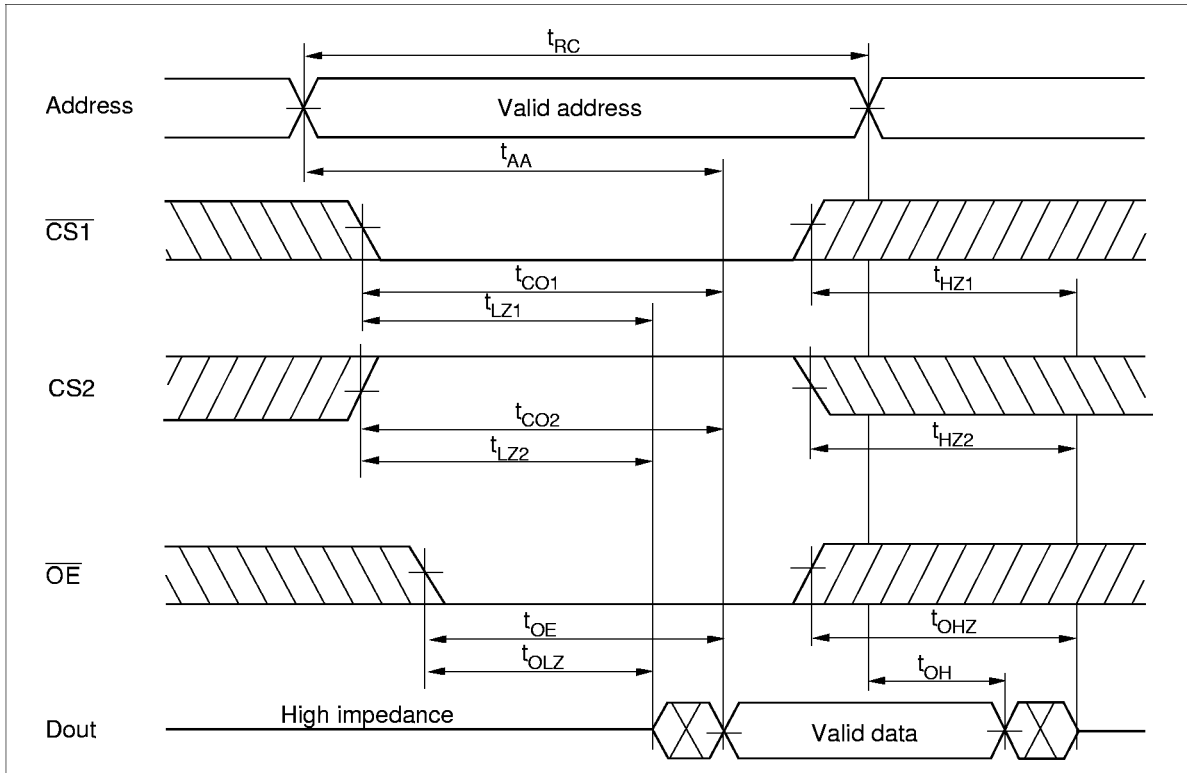

HM628128B Series

Write Timing Waveform (1) (\overline{OE} Clock)

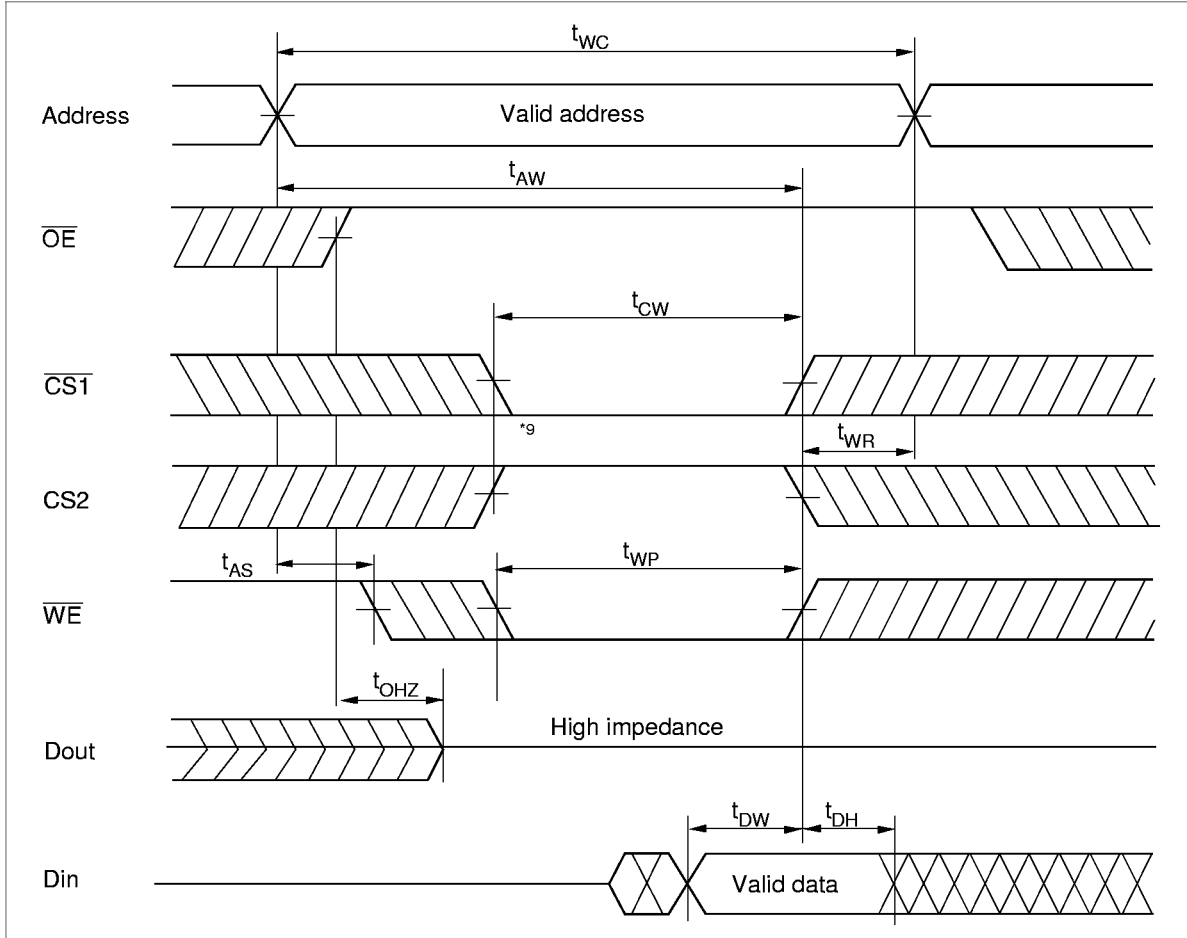

Write Timing Waveform (2) (\overline{OE} Low Fixed)

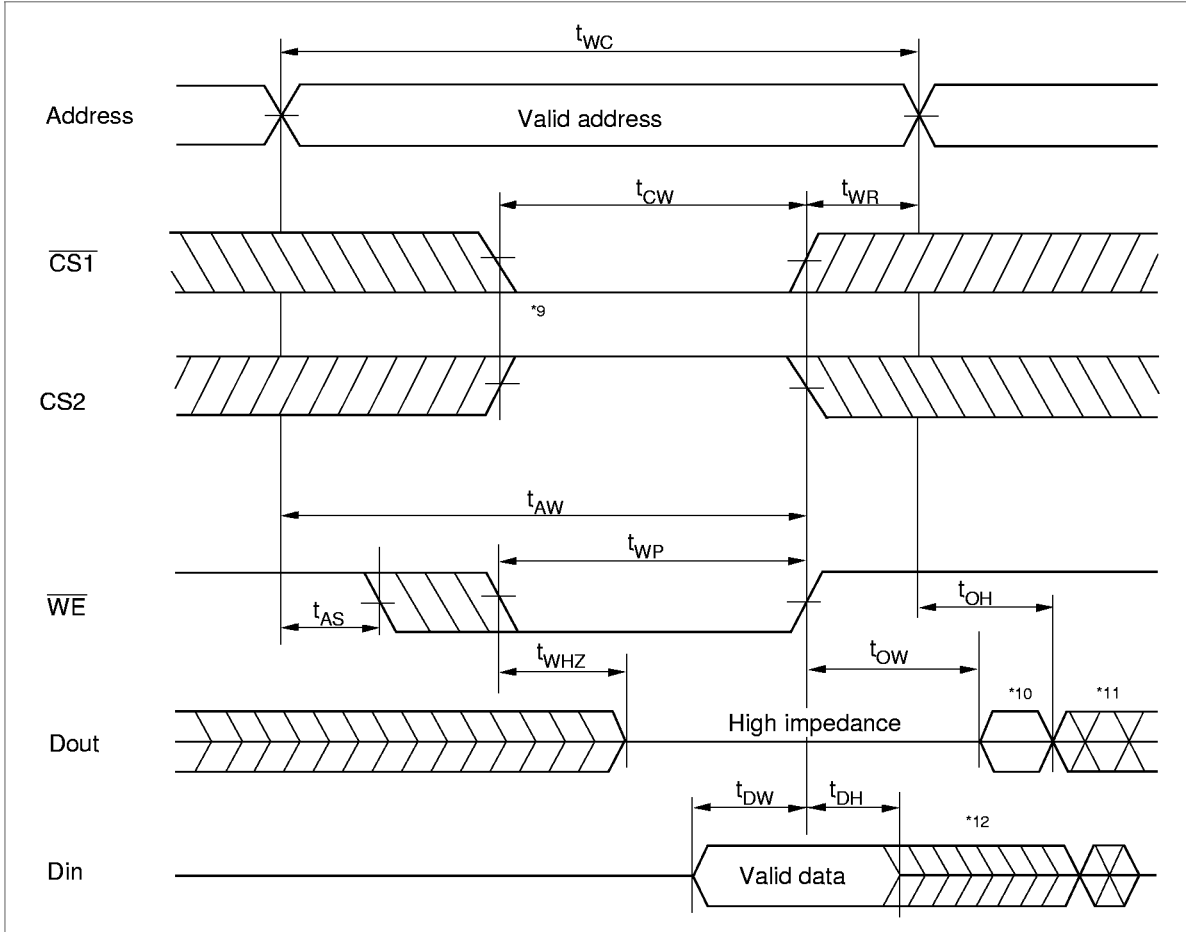

HM628128B Series

Low V_{CC} Data Retention Characteristics ($T_a = 0$ to $+70^\circ\text{C}$)

Parameter	Symbol	Min	Typ* ⁴	Max	Unit	Test conditions ³
V_{CC} for data retention	V_{DR}	2.0	—	—	V	$0\text{V} \leq V_{in} \leq V_{CC}$ (1) $0\text{V} \leq CS2 \leq 0.2\text{V}$ or (2) $CS2 \geq V_{CC} - 0.2\text{V}$ $CS1 \geq V_{CC} - 0.2\text{V}$
Data retention current	I_{CCDR}	—	1	50^{11}	μA	$V_{CC} = 3.0\text{V}$, $0\text{V} \leq V_{in} \leq V_{CC}$ (1) $0\text{V} \leq CS2 \leq 0.2\text{V}$ or (2) $CS2 \geq V_{CC} - 0.2\text{V}$, $CS1 \geq V_{CC} - 0.2\text{V}$
	I_{CCDR}	—	1	15^{12}	μA	
Chip deselect to data retention time	t_{CDR}	0	—	—	ns	See retention waveform
Operation recovery time	t_R	5	—	—	ms	

- Notes: 1. This characteristic is guaranteed only for L version, $20\ \mu\text{A}$ max. at $T_a = 0$ to 40°C .
 2. This characteristic is guaranteed only for L-SL version, $3\ \mu\text{A}$ max. at $T_a = 0$ to 40°C .
 3. CS2 controls address buffer, \overline{WE} buffer, $\overline{CS1}$ buffer, \overline{OE} buffer, and Din buffer. If CS2 controls data retention mode, V_{in} levels (address, \overline{WE} , \overline{OE} , $\overline{CS1}$, I/O) can be in the high impedance state. If $\overline{CS1}$ controls data retention mode, CS2 must be $CS2 \geq V_{CC} - 0.2\text{V}$ or $0\text{V} \leq CS2 \leq 0.2\text{V}$. The other input levels (address, \overline{WE} , \overline{OE} , I/O) can be in the high impedance state.
 4. Typical values are at $V_{CC} = 3.0\text{V}$, $T_a = +25^\circ\text{C}$ and not guaranteed.

Low V_{CC} Data Retention Timing Waveform (1) ($\overline{CS1}$ Controlled)

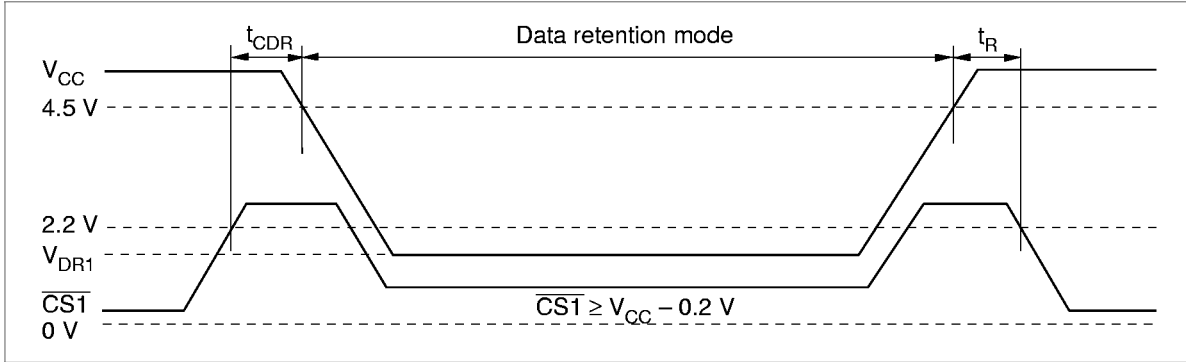

Low V_{CC} Data Retention Timing Waveform (2) (CS2 Controlled)

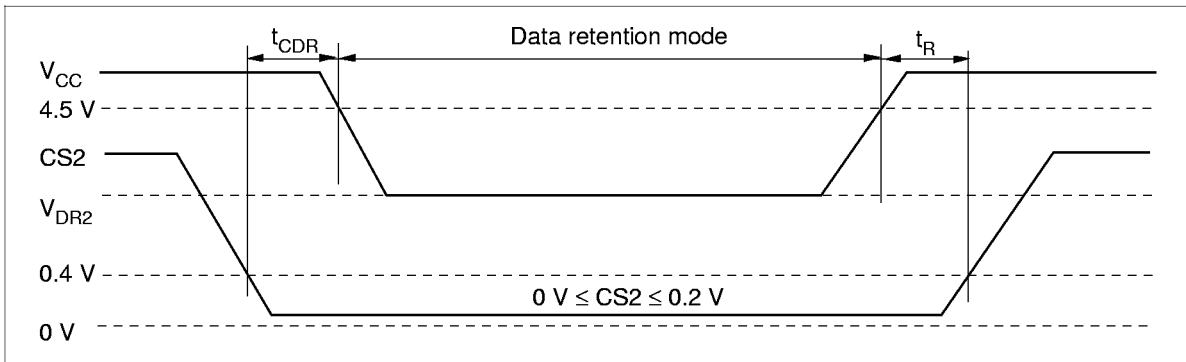

HM628128B Series

Package Dimensions

HM628128BLP Series (DP-32)

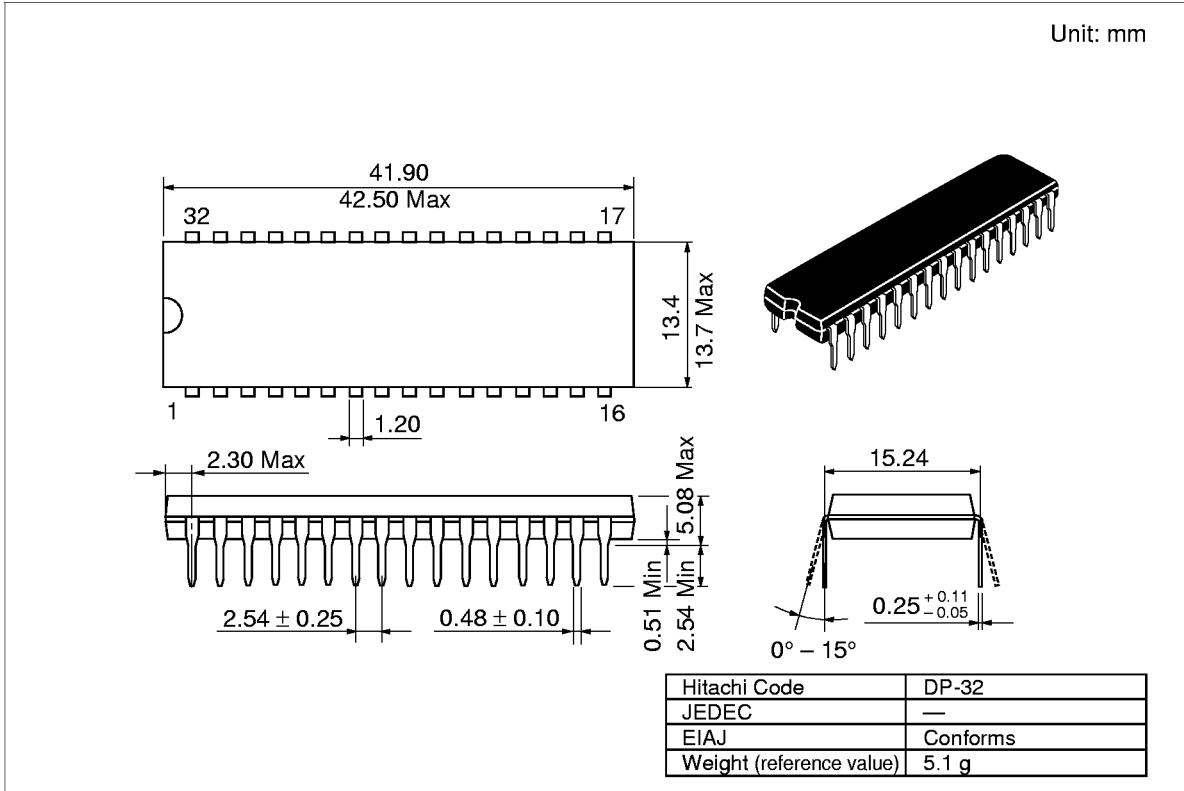

HM628128B Series

Package Dimensions (cont.)

HM628128BLFP Series (FP-32D)

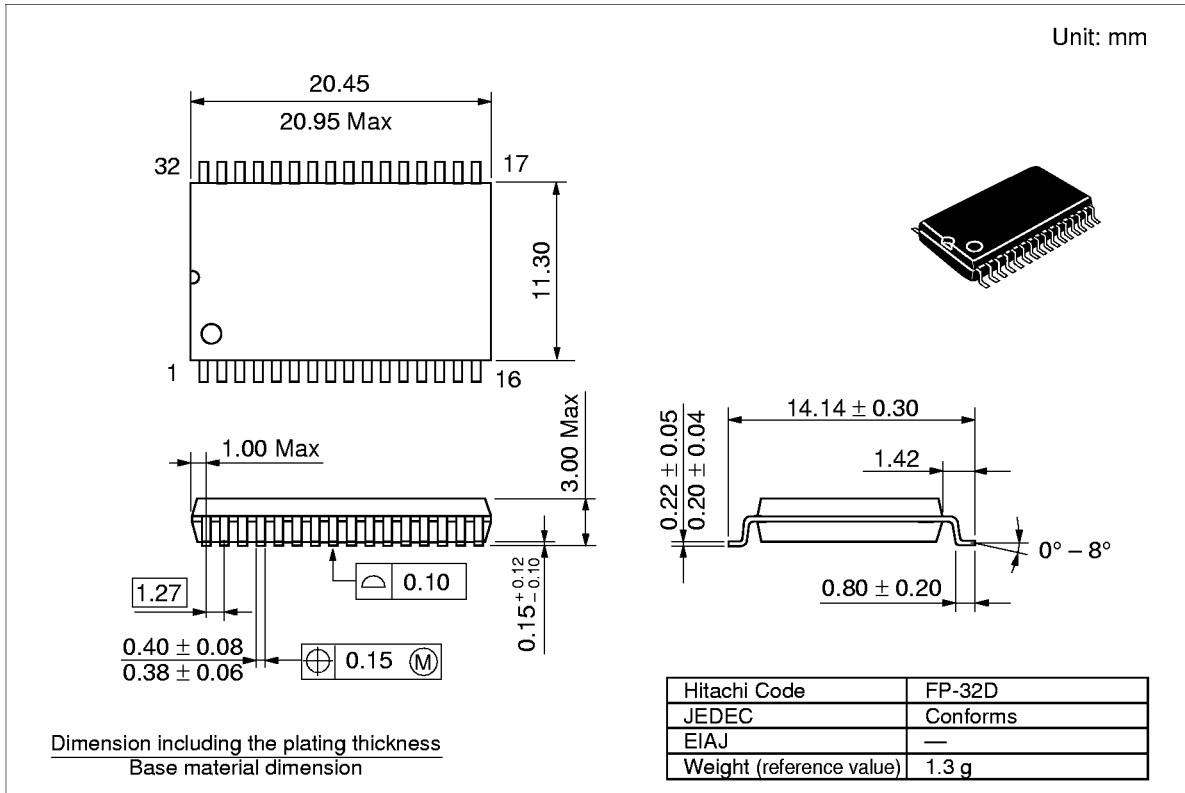

HM628128B Series

Package Dimensions (cont.)

HM628128BLT Series (TFP-32D)

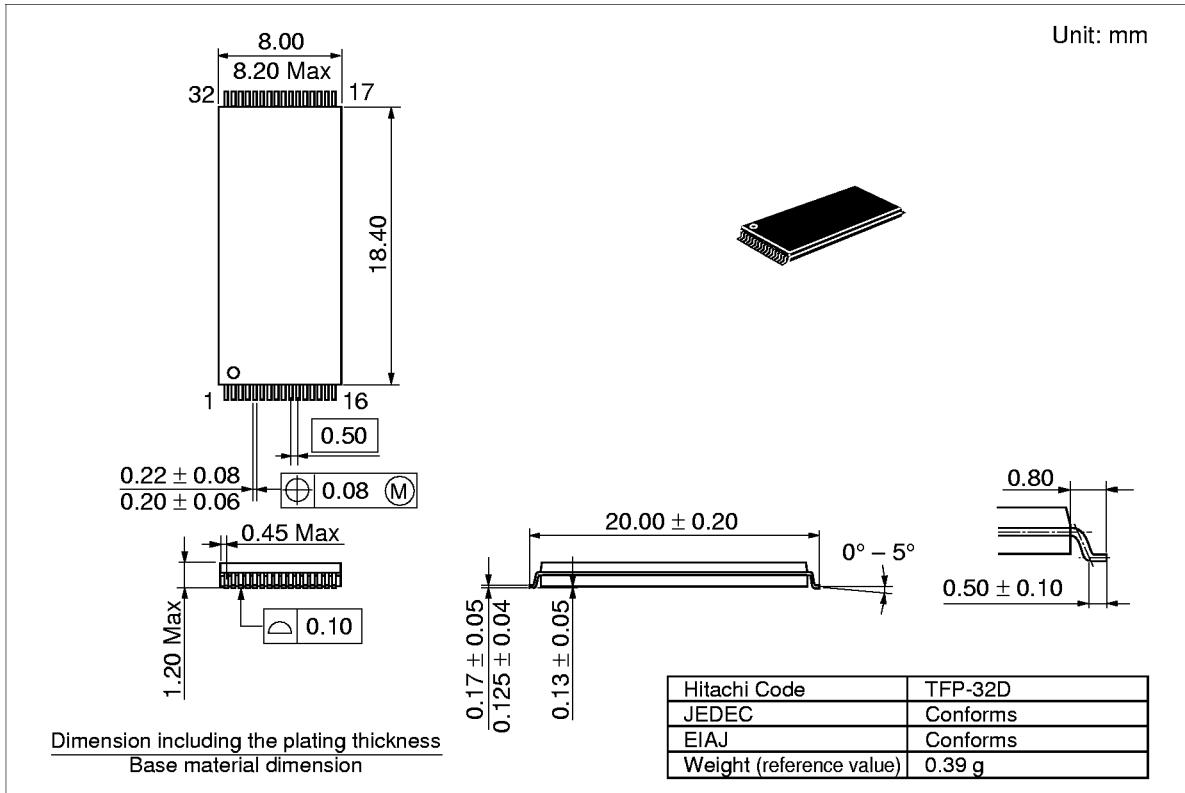

HM628128B Series

Package Dimensions (cont.)

HM628128BLR Series (TFP-32DR)

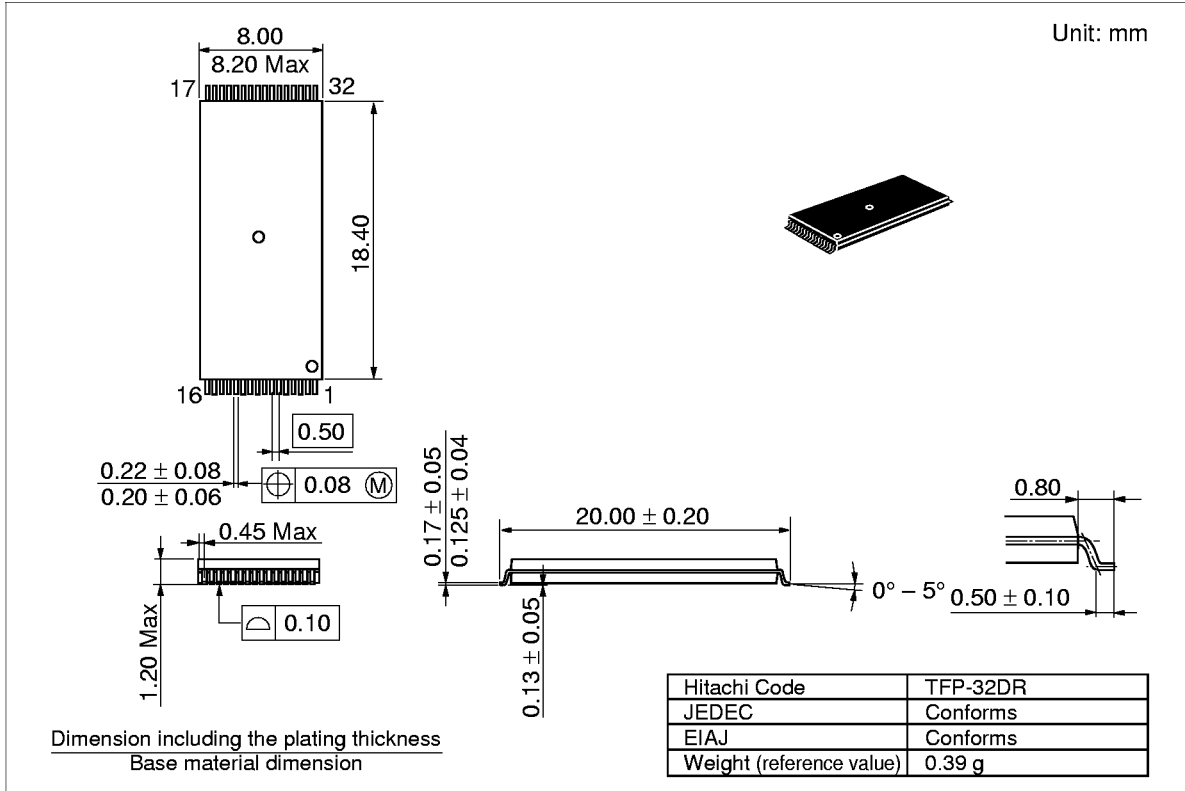

HM628128B Series

When using this document, keep the following in mind:

1. This document may, wholly or partially, be subject to change without notice.
2. All rights are reserved: No one is permitted to reproduce or duplicate, in any form, the whole or part of this document without Hitachi's permission.
3. Hitachi will not be held responsible for any damage to the user that may result from accidents or any other reasons during operation of the user's unit according to this document.
4. Circuitry and other examples described herein are meant merely to indicate the characteristics and performance of Hitachi's semiconductor products. Hitachi assumes no responsibility for any intellectual property claims or other problems that may result from applications based on the examples described herein.
5. No license is granted by implication or otherwise under any patents or other rights of any third party or Hitachi, Ltd.
6. **MEDICAL APPLICATIONS:** Hitachi's products are not authorized for use in **MEDICAL APPLICATIONS** without the written consent of the appropriate officer of Hitachi's sales company. Such use includes, but is not limited to, use in life support systems. Buyers of Hitachi's products are requested to notify the relevant Hitachi sales offices when planning to use the products in **MEDICAL APPLICATIONS**.

HITACHI

Hitachi, Ltd.

Semiconductor & IC Div.
Nippon Bldg., 2-6-2, Ohte-machi, Chiyoda-ku, Tokyo 100, Japan
Tel: Tokyo (03) 3270-2111
Fax: (03) 3270-5109

For further information write to:

Hitachi America, Ltd.
Semiconductor & IC Div.
2000 Sierra Point Parkway
Brisbane, CA. 94005-1835
U S A
Tel: 415-589-8300
Fax: 415-583-4207

Hitachi Europe GmbH
Continental Europe
Dornacher Straße 3
D-85622 Feldkirchen
München
Tel: 089-9 91 80-0
Fax: 089-9 29 30-00

Hitachi Europe Ltd.
Electronic Components Div.
Northern Europe Headquarters
Whitebrook Park
Lower Cookham Road
Maidenhead
Berkshire SL6 8YA
United Kingdom
Tel: 01628-585000
Fax: 01628-585160

Hitachi Asia Pte. Ltd.
16 Collyer Quay #20-00
Hitachi Tower
Singapore 049318
Tel: 535-2100
Fax: 535-1533

Hitachi Asia (Hong Kong) Ltd.
Unit 706, North Tower,
World Finance Centre,
Harbour City, Canton Road
Tsim Sha Tsui, Kowloon
Hong Kong
Tel: 27359218
Fax: 27306071

Copyright © Hitachi, Ltd., 1997. All rights reserved. Printed in Japan.

HM628128B Series

Revision Record

Rev.	Date	Contents of Modification	Drawn by	Approved by
0.0	Oct. 5, 1994	Initial issue	M. Higuchi	K. Yoshizaki
1.0	Dec. 20, 1994	DC Characteristics I_{CC} max: 15 mA to 25 mA I_{CC2} typ: 5 mA to 10 mA I_{CC2} max: 10 mA to 20 mA	M. Higuchi	K. Yoshizaki
2.0	Mar. 20, 1995	Low Vcc Data Retention Characteristics Addition of note 3: typical values at $V_{CC} = 3.0$ V, $T_a = +25^\circ\text{C}$ and not guaranteed	M. Higuchi	K. Yoshizaki
3.0	Aug. 10, 1996	Change of format Addition of HM628128B-10/10SL Series AC Characteristics Change order of note.	M. Higuchi	K. Yoshizaki
4.0	Jul. 1, 1997	Addition of HM628128B-75 Series DC Characteristics V_{OH} Test condition: -0.1 mA to -1.0 mA	M. Higuchi	K. Imato
5.0	Nov. 1997	Change of Subtitle		
